



HEIDENHAIN

60 + 10/2014

Klartext

News from the World of HEIDENHAIN Controls

TNC 640 – the High-End Control

New Options for Machining

**Dynamic
efficiency
convinces
in practice**



Klartext

60 + 10/2014

Editorial

Dear Klartext Reader,

You've been familiar with the name Klartext for a long time now—as the conversational language for programming TNC controls and also as the title of this magazine. In both cases it characterizes a simple, direct and easily understandable method of communication, without any misconceptions, digressions or codes.

We aim to expand this open type of communication, so that in the future we'll be bundling all information and communication platforms concerning our TNC controls and their operation under the Klartext name. As a result, in addition to Klartext programming and the Klartext magazine, you can now access the Klartext portal (www.klartext-portal.de) on the Internet.

No matter how and where you become informed about HEIDENHAIN controls and how you wish to contact us: Klartext is always the right catchword for the complete range of TNC topics.

A fact that is proven by this edition of the Klartext magazine—many new features and functions of the TNC 640 are presented in a clearly understandable way. Users also report how and why they use HEIDENHAIN controls in their production cycles.

Read and enjoy, with best wishes from the Klartext staff!



Ideal for high-precision, full-surface machining: The TNC 640 in the Grimseil Hydro maintenance workshop.



Industry 4.0: Recording of machine data directly from the TNC.



www.klartext-portal.com

Production

Publisher

DR. JOHANNES HEIDENHAIN GmbH
Postbox 1260
83292 Traunreut, Germany
Tel: +49 8669 31-0
HEIDENHAIN on the Internet:
www.heidenhain.de



Content

The future begins now

The TNC is ideally equipped for tomorrow's production 4

The TNC 640 for state-of-the-art power plant technology

How the Grimsel Hydro maintenance workshop equips itself for the future 6

Parts producer upgrades to full-surface machining

A HERMLE machining center with HEIDENHAIN TNC 640 expands the range of services 10

Unbreakable – Milled from Solid Material

Custom bikes made by Thunderbike 12

Practice-oriented fine-tuning for workshops

The latest software version 04 for the TNC 640 14

Dynamic efficiency convinces

Users and scientists test ACC, AFC and trochoidal milling 17

LAC increases precision and saves time

The LAC dynamic precision function in a performance test 18

Efficiency at its best

Recording of machine data directly from the iTNC 530 20

TURN PLUS: NC program at the push of a button

In record time: From the drawing to the finished part 24

Milling without collisions thanks to DCM

Dynamic Collision Monitoring (DCM) from HEIDENHAIN at KERN Microtechnik 26

Intelligent milling with residual material detection

iTNC 530 with software version 04 29

The right choice for good service

Spotlight on: Functional and premium repair in practice 30



Responsible

Frank Muthmann
E-mail: klartext@heidenhain.de
Klartext on the Internet:
www.klartext-portal.de

Editing and layout

Expert Communication GmbH
Richard-Reitzner-Allee 1
85540 Haar, Germany
Tel: +49 89 666375-0
E-mail: info@expert-communication.de
www.expert-communication.de

Photo credits

KWO, Robert Bösch: Pages 6 and 9
KWO, Schemagrafik: Pages 8, 9
OPEN MIND: Pages 12, 13
All other images
© DR. JOHANNES HEIDENHAIN GmbH

The future begins now

The TNC is ideally equipped for tomorrow's production

Successful new products unite technological progress with the dependable strengths of their predecessors, and are also future-safe. This principle also applies to the new TNC 640, adding innovative functions and the necessary potential for the future to the typical strengths of TNC controls. As a consequence, the system will not only support coming developments in control technology but decisively shape these, as many HEIDENHAIN controls have also done in the past.

Workshop-oriented programming, a uniform operating concept and program compatibility were and continue to be the strengths of HEIDENHAIN TNC controls, in addition to over 35 years of consistent development of highly practical functions. From generation to generation, TNC controls have significantly contributed to improving machining quality and have achieved increased process safety and productivity. The TNC 640 is also guided by this tradition, supporting the functions of its predecessors while at the same time providing many new options for machining.

Improved: 3-D graphic simulation

With the new, finely detailed 3-D graphic simulation of the TNC 640, operators can precisely evaluate the result of milling, drilling or turning processes before actual machining. This means they can detect critical tool motions in good time and quickly carry out necessary modifications to minimize scrap and avoid damages to machines and tools.

More capabilities: Milling and turning in one setup

The TNC 640 enables combined milling and turning operations on the same machine, meaning that the system not only saves space and money for another machine, but manufacturing also benefits from increased precision and productivity because workpiece rechucking is no longer necessary. Users can switch as desired between turning and milling within an NC program. The TNC 640 implements this switching and all requisite modifications, while standard path functions, free contour programming, conversational programming and comprehensive cycles mean that the programming and performing of turning operations for newcomers coming from milling is highly simple.

Greater precision: Clean surfaces, perfect contours

With Advanced Dynamic Prediction (ADP) and **Dynamic Precision** functions, the TNC 640 enables the machining of components with clean surfaces and perfect contours in shorter time periods. ADP dynamically calculates the contour in advance, and can therefore use acceleration-limited motion control with smoothed jerk to adapt the axis velocity in good time at contour transitions. In this way the function permits optimized motion control of the feed axes with 3- and 5-axis milling. **Dynamic Precision** brings together the competing demands of precision, high surface quality and short machining times with specially-designed functions counteracting the effects of misalignments and oscillations of the machine and machining process with intelligent control technologies.





The high-end control for milling and milling-turning

Simpler: Concise operation

HEIDENHAIN has fine-tuned both the user interface and the handling of the TNC 640 to make the control more simple and user-friendly. The results:

- The concise display of NC programs with user-friendly screens and modern color design
- A higher-performance editor
- The simplified handling of DXF files
- The direct display of PDF files on the control
- A context-sensitive cutting-data calculator, enabling simple and quick calculation of technology data for immediate transfer to the feed rate and speed dialogs

Highly practical probing functions and various calibration cycles on the TNC 640 mean that setting up the machine is simple and convenient, and they also ensure high process safety without the disruption of ongoing processes.

More informative: TNC 640 workshops in the HEIDENHAIN training center

Have we aroused your interest? Satisfy your thirst for knowledge live on the machine! The HEIDENHAIN training center in Traunreut offers special, free user workshops for this purpose, presenting the key features and latest innovations of the TNC 640—a live demonstration is worth more than a thousand words! Take a look at training.heidenhain.de in the "Training program > User workshops" section and find out about the latest dates and details.

[+ training.heidenhain.co.uk/en_UK/home/](http://training.heidenhain.co.uk/en_UK/home/)



The TNC 640 for state-of-the-art power plant technology

How the Grimsel Hydro maintenance workshop equips itself for the future



The day was shrouded with fog, leaving the rugged mountains of the Swiss Alps merely a distant blur. The Klartext team trekked relentlessly over the pass, the Grimsel Lake was barely visible. The lake is one of five reservoirs that supplies the Oberhasli power plant network (KWO for short) with energy to generate electricity for 1.2 million people. Hydroelectric power has always been tapped, but the energy market, especially in recent times, is in a state of transition. The Grimsel Hydro maintenance workshop at Innertkirchen is the in-house workshop for the power plant, and adapts its infrastructure according to needs: The brand new REIDEN RX 18 5-axis machining center equipped with the latest HEIDENHAIN control—the TNC 640—was reason enough for the Klartext team to find out more.

The KWO, managing nine power plants, had already set up a central maintenance and repair shop in the 1970's. The network has also been providing its overhauling service to other power stations since the beginning of 2000, consisting specifically of repairing and modernizing heavily loaded turbines, pumps and shut-off elements. Grimsel Hydro has established its expertise over the years, and has to function ever more economically due to liberalized electricity markets and the resultant cost and competition pressure. In addition, lead times should also remain short. The new REIDEN RX 18 5-axis machining center with rotary table, trigonal milling head and TNC 640 control contributes to this need for improving efficiency during the complex maintenance work.

Rapidly productive and keen on the new 3-D graphics

"It was simply very good," summarized Martin Seiler, Head of Production at Grimsel Hydro. The Klartext team needed a little time to get used to the Swiss-German dialect. "We were positively surprised," stated the manager, referring to rapid use following commissioning of the new mill-

ing-turning center. His team was able to machine the very first parts in a very short space of time, also thanks to the fact that getting used to the HEIDENHAIN control is relatively straightforward. The machine operator Nils Wettach commented: "I get along just fine." He machines only single parts and also programs almost everything on the machine, and the many cycles mean that he can rapidly generate NC programs.

Nils Wettach is particularly keen on the new graphic simulation of the TNC 640. "I always take a look at the simulation beforehand to make sure the tool moves how I want it to." He sets the view precisely as he needs it—with tool and tool paths, with highlighted workpiece edges or with transparent display. He easily zooms, rotates or shifts the 3-D graphics via soft key or touchpad.

High-precision, full-surface machining cycles for special workpieces

The Klartext team was shown power plant components of impressive sizes and diversity in the machine hall—turbine hous-

Safe for times to come: The Grimsel Hydro maintenance workshop modernizes power plants. It is ideally equipped for the future with the new REIDEN 5-axis RX 18 machining center and HEIDENHAIN TNC 640 control.

Accurate down to the last detail: The new high-resolution 3-D graphic simulation supports analysis of the NC program before machining.

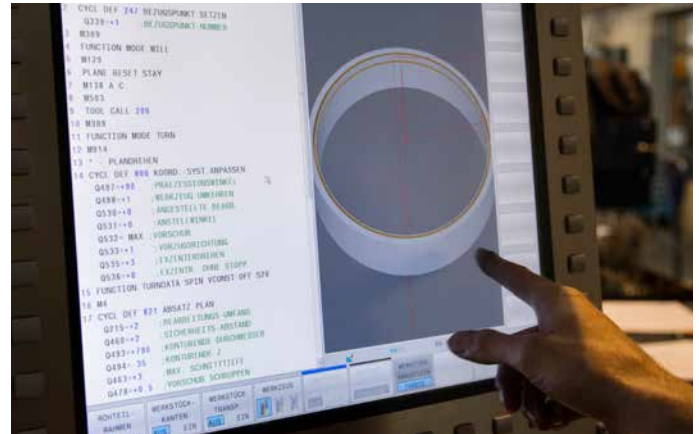

ings, Pelton runners with diameters of 3.80 m and guide blades, as well as shut-off elements such as spherical and throttle valves. These parts are subjected to very high wear due to the force of water, and suspended particles such as sand and small stones in the water cause erosion. Functionality also deteriorates over time due to leakages and sluggishness.

All components are subjected to assessment, and strongly stressed parts are checked for cracks and individually repaired.

Due to limited spatial conditions, the new REIDEN 5-axis RX 18 machining center was certainly the right choice as its compact construction ideally utilizes the space available—Grimsel Hydro would have otherwise needed a new hall. Martin Seiler appreciates the large working space, and particularly the long traverse path in the Z axis. Good accessibility of the machine, including from above, is also an advantage, which is especially important for Grimsel Hydro as handling and clamping the large and heavy power plant components is often tricky as well as costly in terms of time. In this sense, combined milling and turning is exceedingly effi-



cient—the company previously used two separate controls, one for milling and one for turning. A further highlight for difficult-to-access machining: The trigonal milling head can handle machining operations with a solid angle range of -15° to $+105^{\circ}$.

Grimsel Hydro places particular importance on the control itself. “With HEIDENHAIN controls the functions for turning are logically designed, and the same is true for milling,” confirmed Nils Wettach. The TNC 640 provides reliable operation, particularly for unique components.

The new high-end control from HEIDENHAIN helps to achieve high levels of precision, and the KinematicsOpt TNC function compensates for strong deviations in temperature that exist in the hall without air conditioning. The function compensates for offsets in the turning and tilting axes, in order to achieve precise sealing faces, for example.



Field layout: Oberhasli AG power plants

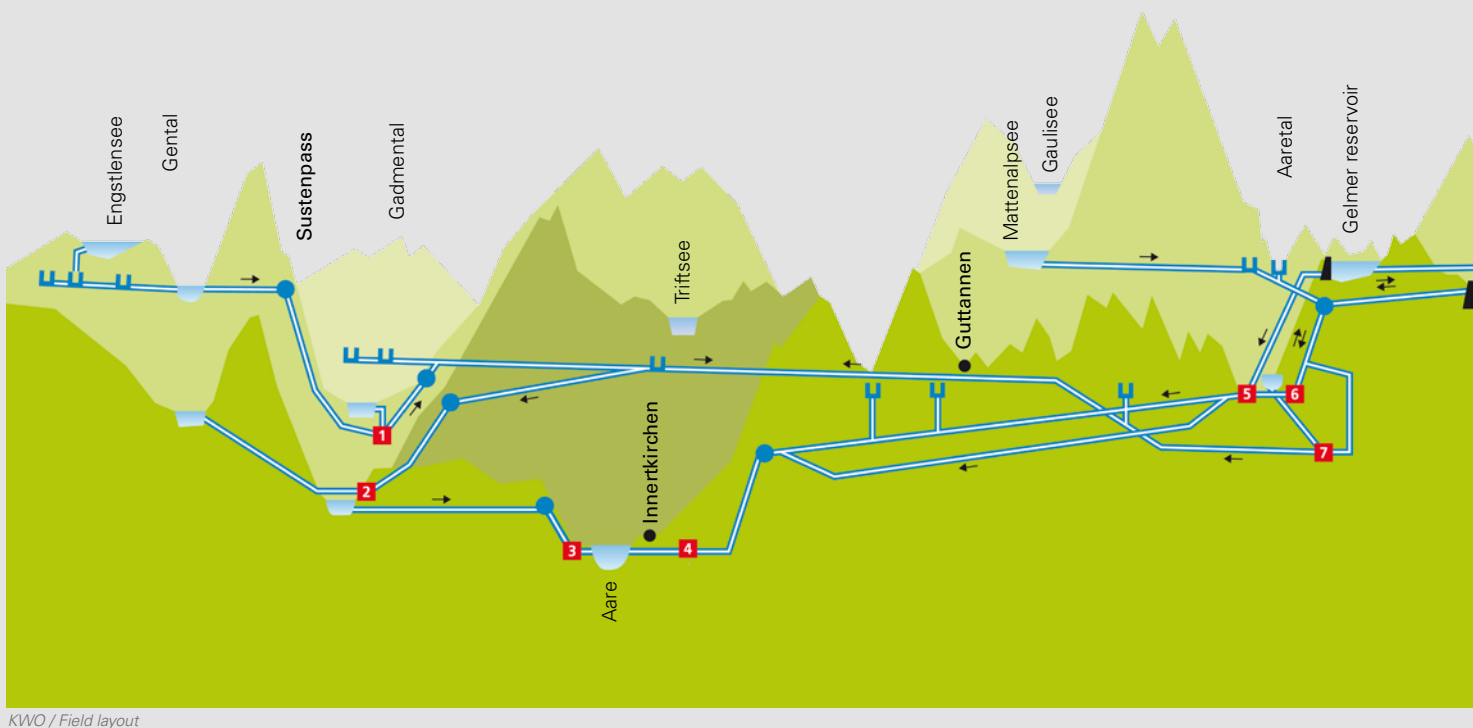



Conclusion

“Everything’s simply become more cost-efficient,” stated Martin Seiler. Grimsel Hydro uses the new REIDEN 5-axis RX 18 machining center in two work shifts. “Our orders can be better coordinated thanks to full-surface machining.” Bearing seats and labyrinth seals need high levels of precision that the machine achieves better in conjunction with the HEIDENHAIN TNC 640. Grimsel Hydro also saves much time thanks to the simple operation of the TNC 640.

Nils Wettach has unlimited freedom of movement with the HEIDENHAIN wireless handwheel, using it for configuring purposes, for example for centric alignment of turned components with the measuring dial.

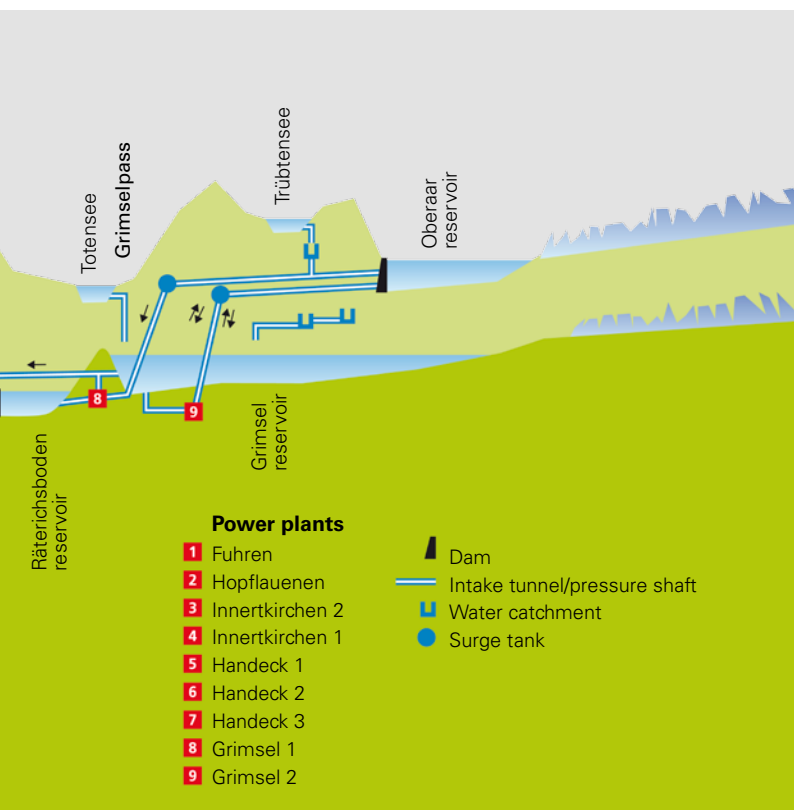

KVO / Overview Grimsel area: Robert Bösch

Grimselstrom facts

- 9 power plants with 26 machines (turbines, pumps), 2 further machines in construction
- Catchment area of 700 million m³ of water per year
- 2400 GWh electricity production per year
- Maximum height: Finsteraarhorn at 4,274 m above sea level

+ grimselstrom.ch



Höcherl & Reisinger produces components with the new HERMLE machine, with combined milling and turning.

Parts producer upgrades to full-surface machining

A HERMLE machining center with HEIDENHAIN TNC 640 expands the range of services



“As a parts manufacturer we have to constantly be both quicker and better,” stated Herbert Höcherl, Managing Director of Höcherl & Reisinger Zerspanungstechnik GmbH. The formula for success of the mid-sized company from the Upper Palatinate region of Germany is to implement the latest technology and exploit its inherent potential. They’ve been doing this for over 20 years. Useful support in this respect is provided by high-performance machining centers from HERMLE, all of which are equipped with HEIDENHAIN controls. A HERMLE C 50 U MT dynamic and the new TNC 640 high-end control with turning option have enabled the company to expand its parts spectrum.

“We aim to be right at the forefront in terms of price, quality and deadlines,” said Herbert Höcherl, and this is the reason why his company consistently implements specific measures to assert its

position in the marketplace. This in turn means using highly skilled employees, automation, and three shifts, as well as producing with the very latest and dependable technology. “The excuse that a defective machine is halting production has never been heard of at our company,” attested the Managing Director. As a consequence of this, Höcherl has an impressive machine park and places its trust throughout in HEIDENHAIN controls, enabling the company to be a reliable partner for customers.

A very wide variety of components passes through the production sequence at Höcherl within tight time frames, ranging from small parts to sophisticated prototypes and fixtures. The materials used are just as diverse—tool steels are machined in addition to stainless steels, aluminum and a variety of plastics, and it’s here that flexibility is needed, both with the machine park and from employees.

Greater speed, accuracy and diversity with milling-turning

Full-surface machining with the HERMLE machining center is new at the company. “We’ve always produced parts by milling and turning,” said Christian Hecht, employed as a toolmaker at Höcherl & Reisinger. Höcherl now produces not only larger parts than before, but mills and turns them with the integral rotary table in a single setup and with simultaneous 5-axis machining thanks to their new “C 50 U MT dynamic.” The combined milling-turning operations are therefore quicker and more accurate. Christian Hecht reminisced: “A few years ago we did the turning operations, we then needed a different fixture and we had to set it up again and then do the milling.” Machining with milling-turning has now become much simpler with many of the parts, and Höcherl estimates that time savings reach 70%.

“Programming turning cycles isn’t difficult at all, even if you come from a milling background.”

Johann Götz, CNC programmer

Easy familiarization with the new TNC 640 control

From the beginning, Höcherl & Reisinger has consistently relied on HEIDENHAIN controls, and so the company’s training programs have a TNC 155 and TNC 426 in addition to state-of-the-art controls. “This makes it easier to place our employees on a variety of machines.” Herbert Höcherl sees the main advantage in this factor as well as in simple operation.

No problems at all were experienced during the familiarization process with the new TNC 640. “It’s really quite easy,” said Johann Götz, a CNC programmer who together with Christian Hecht supervises the new machining center. “Programming turning cycles isn’t difficult at all, even if you come from a milling background.” The uniform operation of milling and turning

functions contributes to this factor—turning cycles are designed in the same way as milling cycles with the TNC 640, with the result that operators quickly find their way around. “The difficulties lie more in identifying optimal cutting parameters and speeds rather than getting to know the programming of turning cycles,” explained Mr. Götz. The upgraded interface is popular with the machine operators, “because you get a good overview at just a quick glance,” said Götz.

A new parts spectrum created

Herbert Höcherl is confident that his investment in the new machine was the correct decision, and on the one hand, with the new HERMLE machine, he has created potential for a wider portfolio of workpieces, stating “We can now turn diameters of 1 meter.” On the other hand, as a supplier Höcherl sees itself optimally positioned, with regard to the fact that “All of our customers need their parts within three weeks.” The Managing Director is now able to meet such tight deadlines thanks to good cutting performance and the capability of full-surface machining.

Conclusion

With the new, high-end HEIDENHAIN TNC 640 control and turning option, upgrading to full-surface machining, i.e. combined milling and turning in one setup, is simple to master. Höcherl’s employees, formerly mainly used to milling, became rapidly familiar with turning thanks to the simple and uniform operation.

**Höcherl & Reisinger
Zerspantechnik GmbH**

Höcherl & Reisinger Zerspantechnik GmbH is a parts manufacturer with headquarters in Walderbach, near Regensburg, Germany. The mid-sized company has been producing workpieces for mechanical engineering and apparatus construction, ranging from prototypes to series products, since 1991. The company’s fixture construction also produces and assembles clamping devices and deburring tools.

+ www.hoecherl-reisinger.de

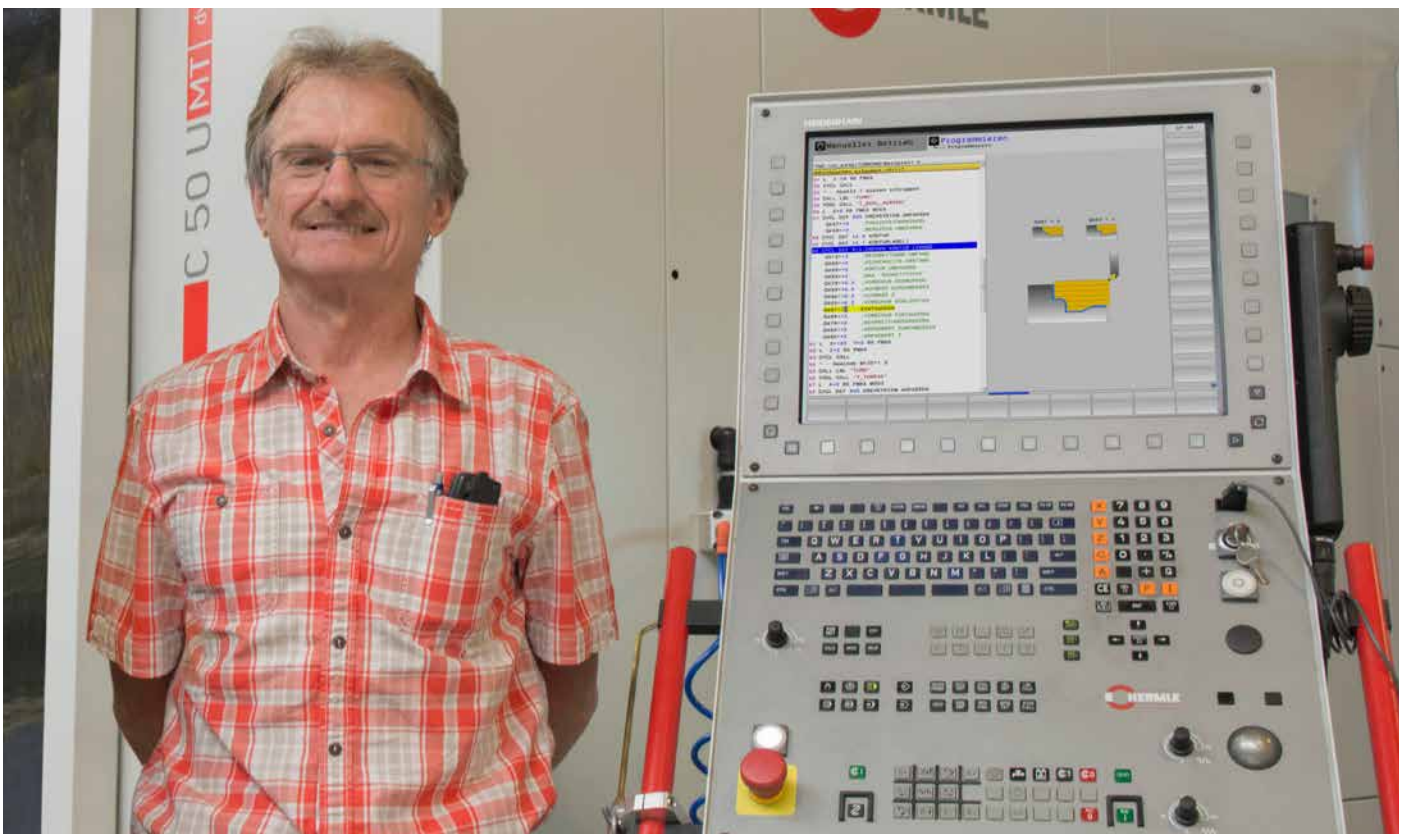

Managing Director Herbert Höcherl is highly pleased about expanding his parts spectrum thanks to the company’s new machining center equipped with the TNC 640.

Unbreakable – Milled from Solid Material

Custom bikes made by Thunderbike

Thunderbike is one of the top addresses for individual custom bikes in Germany. In 2013 the company presented its “Unbreakable” custom project for the first time at the European Bike Week at Lake Faaker in Austria, the largest Harley get-together in Europe. The public showed much enthusiasm for the cruiser with sweeping Art Déco-style curves and an extremely low seat position. Countless turned and milled components give the bike its unique form and individual flair, all machined on modern 5-axis machining centers with TNC controls from HEIDENHAIN.

“Unbreakable” – the coherent, complete concept of technology and design, with perfect implementation down to the last detail.

Thunderbike uses original Harley Davidson parts for the complete drive components and electronics, but all other parts are produced in-house. The self-constructed, milled parts are a particular Thunderbike specialty: Fork bridges, turn signals, wheels, radiator grills, stops, hand grips, gas caps and seats are all milled in the company’s workshop, sometimes with highly stylish ornamentation. The engine and gearbox covers are produced to match the other components and feature the typical parallel ribs.

A highly productive chain of processes

Scribbles and technical drawings are used to integrate the customer’s ideas into the concept phase. Thunderbike places its trust in hyperCAD® and hyperMILL® for CAD/CAM implementation, and has created a sector-pioneering process chain that includes machines equipped with HEIDENHAIN controls. All components are modeled and constructed in the CAD system and receive their harmonious look during this phase, with the complete project expanding in a virtual kit of components where appearance, fitting accuracy and assembly capability are ideally matched and assessed.



hyperCAD® is simultaneously used in supplementary areas for machining and vendor parts. "With hyperCAD® we're simply more flexible, especially with free-formed surfaces when nearing actual production," said Herbert Niehues, responsible for the planning and production of components.

Graphic simulation of the machining cycles is highly important, because with turning/milling using 5-axis technology the DCM (dynamic collision monitoring) function provides the necessary safety to run the planned cycles on the machine. The ideal interplay between the CAM system and the HEIDENHAIN TNC 640 control is the result of a close cooperation between both manufacturers. "Precision of the faces is very high because the new control and the machine are able to implement the tighter points defined in the CAM system."

Workshop-oriented control technology

The complete CNC machine park for milling and turning is equipped with HEIDENHAIN controls. The highlight is the new turning-milling center with a TNC 640 control. "HEIDENHAIN has even further improved machining performance with the TNC 640," stated Herbert Niehues. "We're really keen on the new user guidance and we consistently receive updates. The large package of turning cycles, constant cutting speed and tool-tip radius compensation are certainly significant benefits of the control."

Premium design, professionally realized

The result can really be seen. An ideal example are the newly designed wheels of the Unbreakable – a 26" diameter at the front and 21" at the back, with their inner free-form areas being reminiscent of turbine blades. These aesthetic highlights are initially machined on the new turning-milling center from an aluminum block at a maximum speed of 800 rpm. The contours are then produced with 5-axis simultaneous milling. "For us this means less rechucking as well as shorter equipping and idle times," said Herbert Niehues. The previous six work cycles on three different machines were reduced to just three work cycles on the turning-milling center.

Following initial milling, the wheels are anodized by an external company, then fixed on the machine again for milling the outer edges and creating the metallic contrast to the matte coating. The TNC 640 once again provides the right strategy for this task—with 5-axis contour milling the tool is always inclined at the same angle to the face, ensuring that the width of the milling path remains constant.

Everything fits

The Unbreakable is a masterful art work of all milled parts and an example of ideal implementation using HEIDENHAIN control technology. The decorative ribs and struts always fit precisely, and complement each other in terms of design. The spectacular bike with its unusual design was the recipient of no less than three titles at the Bike Week at Lake Faaker. It's exciting to anticipate the next work of art to come from the forge of the Thunderbike craftsmen.

"Our custom bikes serve a highly exclusive clientele," said Andreas Bergerforth, Managing Director of Thunderbike. The custom motorcycles are produced or converted precisely to the desires of the owners, and the increasing international success of Thunderbike is also the consistent result of the company participating in important competitions hosted by the custom bike community. "What makes the difference is the outstanding design and high quality of our unique bikes."

+ www.thunderbike.de/galleries/tb_galleries/unbreakable_mof.php

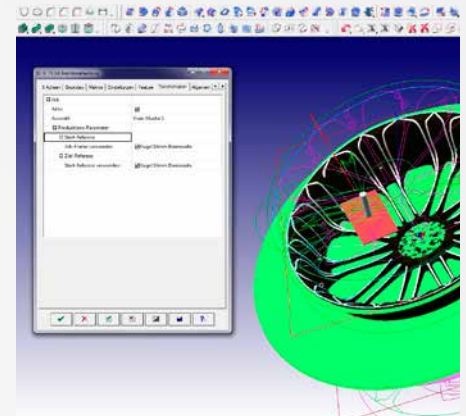

All components receive their coherent design via the SolidWorks CAD system.



Herbert Niehues saves much equipping and idle time during production planning with the TNC 640.



The 3-D milled Unbreakable wheel is machined from a solid aluminum mono-block.

Practice-oriented fine-tuning for workshops

The latest software version 04 for the TNC 640

The TNC 640, the high-end control for milling and milling-turning, gains several new optimizations for workshop use thanks to the latest software version 04.

Simple programming of AFC

Adaptive feed control (AFC) is used with heavy cutting and roughing, automatically regulating the feed rate of the TNC according to a specific reference power.

The new software version now contains a HEIDENHAIN standard syntax for the AFC function. Where complex FN17 blocks previously existed, the learning step needed for AFC can now be carried out much more simply.

Line chart displaying the momentary spindle power and adapted feed rate with the AFC function.



AFC learning step

The TNC 640 stores reference values from the AFC learning step that are accessed later during machining.

To initiate the learning step within defined NC program blocks, enter **FUNCTION AFC CUT BEGIN** in the NC program. Then conclude this learning step via **FUNCTION AFC CUT END** or manually with the **End Learning** soft key.

Alternatively, the AFC learning step can also be controlled with **FUNCTION AFC CUT BEGIN TIME1 DIST2 LOAD3**:

- **TIME** concludes the learning step after expiration of a defined time.
- **DIST** concludes the learning step after reaching a defined path.
- The TNC needs no learning step with **LOAD**, immediately starting operation with a previously defined reference power.

AFC control operation

New features are functions that start and stop AFC operation while an NC program is running.

Initiate AFC control operation with **FUNCTION AFC CTRL** and stop it with **FUNCTION AFC CUT END**.

Context-sensitive cutting data calculator

Glowing chips, built-up edges and chipped edges are the result of incorrectly calculated feeds and speeds. The right technology data must be determined by the machine operator using data manuals and pocket calculators according to the characteristics of the workpiece and tool material.

This is achieved much more conveniently with the new, context-sensitive cutting-data calculator. The calculator is activated with the **CUTTING DATA CALCULATOR** soft key, displayed as soon as you are in a feed or speed dialog. During programming, the TNC 640 identifies the open dialog window and queries the required input data. Simply then adopt the calculated value via soft key into your feed or speed dialog.

In the **TOOL CALL** block the tool radius previously defined in the tool table is transferred to the cutting-data calculator with the **ACCEPTTOOL RADIUS** soft key.

The cutting-data calculator can also be called up via the pocket calculator function: Press the **CALC** key first and then the **CUTTING DATA CALCULATOR** soft key.

New function	TNC 640	iTNC 530
AFC standard syntax	✓	✓
Cutting data calculator	✓	
Face milling axial (Cycle 233)	✓	
Eccentric turning	✓	

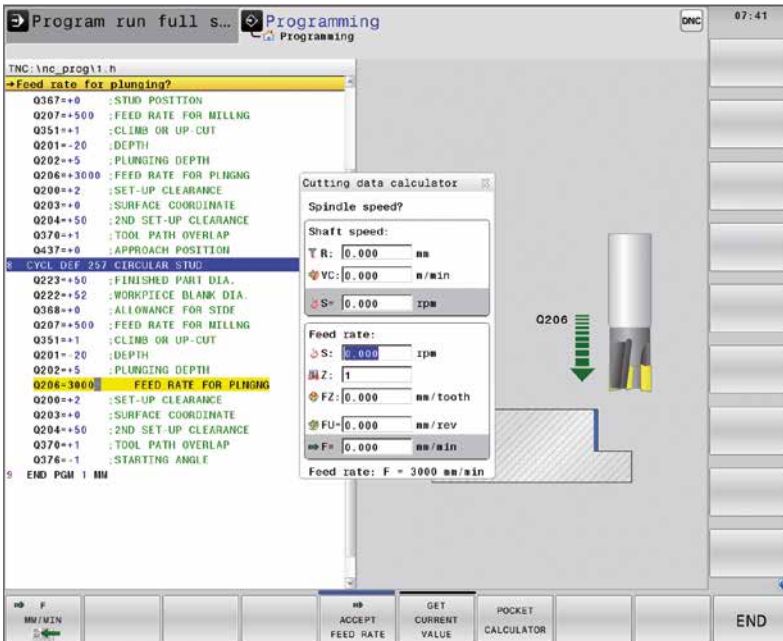

R: Tool radius
 VC: Cutting speed
 S = Spindle speed

S: Spindle speed
 Z: Number of teeth/tool edges
 FZ: Feed per tooth/edge
 FU = Feed per revolution
 F = Feed per minute

New 233 Face Milling cycle

Face milling cycles have long been a feature of TNC. But the new **face milling cycle 233** can do far more than only machine a plane surface in multiple infeeds.

Cycle 233 enables the definition of up to three sides for limiting face machining on side walls or shoulders. Desired corner radii can also be specified for corners generated by adjacent sides.

Machining of the face can be implemented with new, additional machining strategies: Meandering, line-by-line (with or without overrun) or on a spiral from the outside inwards. In addition, the machining direction can also be specified to modify cutting pressure to the current set-up situation. This can be helpful when you want to direct the cutting pressure against the fixed vice jaw.

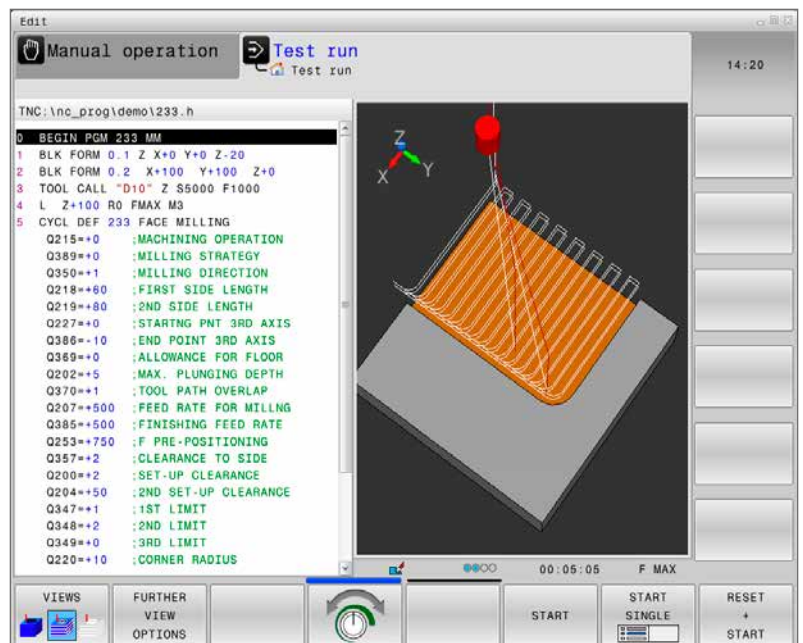

An example: Line-by-line machining of a face with two limits and a corner radius.

Turning eccentric components – simply and efficiently

The production of large and heavy eccentric parts demands complex machining cycles. The new TNC 640 achieves this simply and efficiently with its turning option: The control couples several linear axes to the lathe spindle for producing eccentric workpieces, with these linear axes traversing simultaneously to the eccentric turning center.

This places high demands on both the control and the machine—the linear axes have to achieve high feed rates for generating eccentric rotation of the component. At the same time, though, it is a matter of performing highly dynamic movements with exceptionally high precision to ensure perfect contours and surface quality.

Here's how you program eccentric machining in turning mode with the TNC 640:

First select **CYCL DEF 800 ADJUST XZ SYSTEM**. Cycle 800 positions the milling spindle so that the cutting edge is aligned relative to the turning contour and the coordinate system is adapted accordingly. With this cycle, the last two input parameters affect eccentric turning: **Q535** and **Q536**. Depending on the values entered here, the TNC 640 then performs an eccentric rotary motion. You can select whether the turning center uses the current preset or the current datum, and you can also optionally add a stop before the start of the cycle.

For cutting, select for example the **811 LONGITUDINAL SHOULDER** cycle, position the tool and then call the cycle.

Terminate eccentric machining with the **801 RESET ROTARY COORDINATE SYSTEM** cycle. The settings implemented with Cycle 800 are then reset.

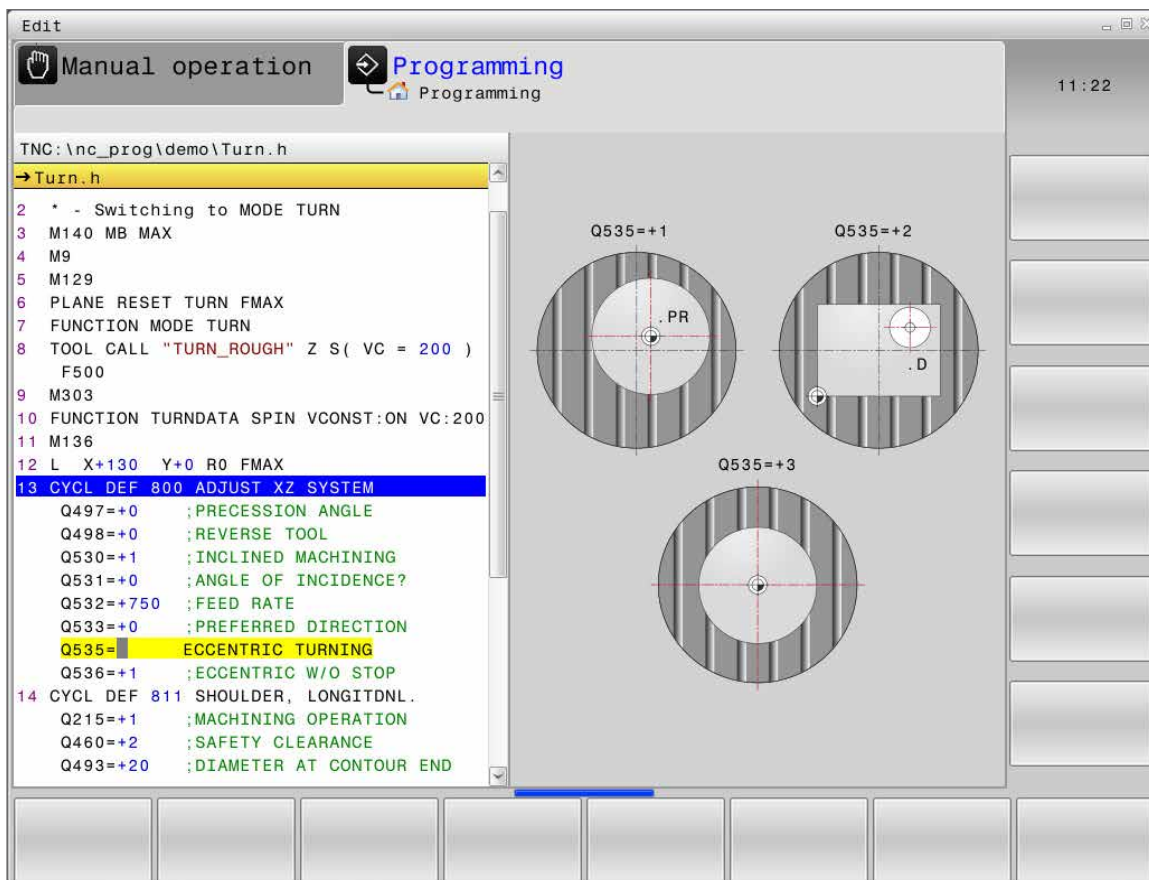

The turning center is selected via parameter Q535.

dynamic + efficiency

Dynamic efficiency convinces

Users and scientists test ACC, AFC and trochoidal milling

Higher material removal rates and greater process safety with heavy machining, i.e. with roughing and the machining of tough materials, and at the same time less load for the machine and tool—such are the demands placed on ACC (Active Chatter Control), AFC (Adaptive Feed Control) and trochoidal milling. Users from North America, France and the Institute of Machining Technology in Dortmund, Germany, confirm that these features fulfill their tasks ideally, and are rightly summarized under the term Dynamic Efficiency.

Utilizing spindle power

In North America the Windsor Mold Group was unable to exploit the complete power of the 52 kW spindle in its machine because chatter occurred with face milling using a six-edged face milling cutter (80 mm diameter) if the axial infeed was 4.5 mm or greater. The activation of ACC together with the machine manufacturer now draws enough energy from these chatter vibrations via the feed drives to increase the infeed to 7 mm, with identical feed rate and spindle speed. The high-performance spindle is therefore utilized more optimally and the material removal rate was increased by 55%. In addition, ACC reduced the vibration amplitudes despite higher infeeds, thereby protecting both the tool and the machine.

When the ground shakes...

Chatter was also a problem for the French company of COUSSO, a supplier near Toulouse of the aerospace industry. When COUSSO started the specified process on the machine, the entire machine hall floor vibrated due to these chatter vibrations, and the tool was worn after a single titanium component. ACC now prevents chattering while retaining the specified process data, thereby reducing the level of vibration to a minimum. The floor of the machine hall no longer shakes, and the tools stay good for significantly longer than just a single component.

Scientifically confirmed

The ISF Dortmund (Institute of Machining Technology) took a detailed, scientific look at the **dynamic efficiency** functions of trochoidal milling and AFC. In their test the experts roughed three pockets with identical widths and depths but with a different machining technology in each case. The tool for all three pockets was a hard metal end mill, and the lengths of the pockets were specified so that all pockets needed the same machining time. The differing pocket lengths thus directly indicate the increased material removal rate:

- Conventional milling technology with full and partial cuts achieved a pocket length of 35 mm in the test.
- With trochoidal milling the machine achieved a pocket length of 45 mm in the same time. A positive side-effect was also the uniform wear of the mill over the complete cutting length due to complete infeed on the Z axis.
- The combination of trochoidal milling and AFC improved performance even more. AFC significantly increases the feed rate in the air cut semicircle of trochoidal milling to increase the pocket length to 55 mm.

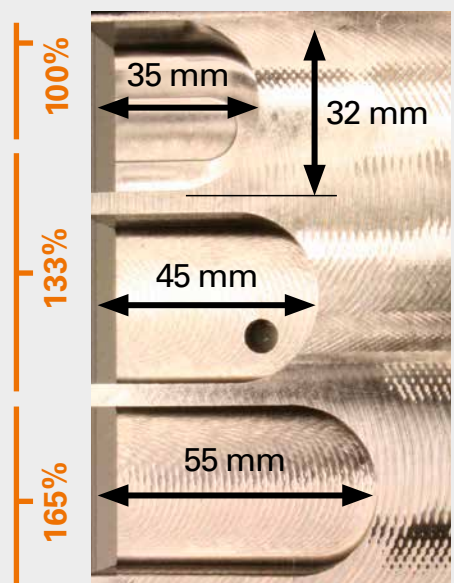

A comparison of milling technologies: Standard milling (above), trochoidal milling (center) and trochoidal milling with AFC (below).



dynamic + precision

LAC increases precision and saves time

The LAC dynamic precision function in a performance test

What does a function that adapts control parameters to the specific load condition of the machine actually achieve? How much does it specifically contribute to overall time savings and machining precision? During a performance test the LAC function (Load Adaptive Control) shows what it's capable of: Thanks to LAC a rotary table performs a complete rotation with 24 acceleration and deceleration processes in 15° steps in just 6 seconds instead of 14 seconds. LAC reduces the following error of the rotary table from 11.5 to 2.2 angular seconds.

Machine operators are always a little skeptical about new functions. This is justified, because changing proven cycles and processes is often tricky and is never done just because of advertising promises. Solid, clear facts on the other hand have a completely different meaning. This is the reason why we subjected the Load Adaptive Control function (abbreviation: LAC) to a performance test that impressively demonstrates its effects.

LAC (Load Adaptive Control) determines the inertia of rotary axes. The function continuously adapts the feed control to the current mass inertia of the workpiece.



Load as a factor of influence

With a machine with workpiece axes, the weight of the workpiece naturally affects the machining, and this is why such machines typically have two or three loading classes for which the machine is configured. These loading classes however are not precise, as they involve weights of up to several hundred kilograms. They therefore only allow an approximation of machine settings to the optimal values. Machine operators must select these manually, representing yet another work step in frequently tight work schedules.

The loading classes also usually only take into account the inherent weight of the component, and with rotary tables this is insufficient. In such cases the inertia is decisive for parameterizing the control, and the mass moment of inertia for a component may be completely different depending on how it is clamped, in worst cases even being multiplied. Here the selection of the loading class provides no help whatsoever because it hardly reflects the state of loading at all.

Poor controller settings are the consequence of such imprecise parameterization, in turn resulting in poor suppression of interferences and vibrations, leading to larger errors during machining. These are particularly noticeable in the acceleration phases. To minimize the occurrence of such errors, the machine dynamics are limited on all axes where the load can significantly change during machining.

A performance test for LAC

In the performance test, LAC was parameterized for the rotary table on a standard machine normally featuring two loading classes. This reduced following error on the axis by more than 50% and considerably increased dynamic precision. With a rotary table motion of 50° and a feed rate of 6000 degrees/min, the following error was reduced from 11.5 to 2.2 angular seconds. With a component radius of 200 mm, the error generated by the rotary axis was reduced from 10.8 µm to 2.1 µm.

The effect of LAC with indexing processes was especially impressive. With many components, a certain subcontour is often repeated at various angles, and in such cases the most simple implementation in a program is the one-time programming of the subcontour and rotation of the rotary axis for machining the other contours at corresponding stepping angles; this is referred to as indexing.

In the performance test the rotary table repeatedly rotates the part by 15°. At each 15° step the axis must briefly accelerate to the maximum feed rate and then immediately decelerate. Machine dynamics significantly increase with the use of LAC, and the possible higher levels of jerk and accelerations reduce the time for each 360° rotation by 57%. With its standard setting without LAC, the machine needs 14 seconds for the above-specified indexing with 24 acceleration and deceleration processes, without machining the component. With parameterization possible via LAC it runs indexing in just six seconds—including the weighing process before the start of machining.

Conclusion

The LAC function, particularly with rotary table movements, achieves significant savings in machining time with simultaneous improvements in precision. The greater the highly dynamic rotation movements needed with strong acceleration and deceleration during machining, the more effective is LAC. The optimization of jerk and acceleration made possible thanks to LAC leads to significant overall savings.



The performance test demonstrates that LAC saves significant time with the repeated machining of subcontours at various angles.

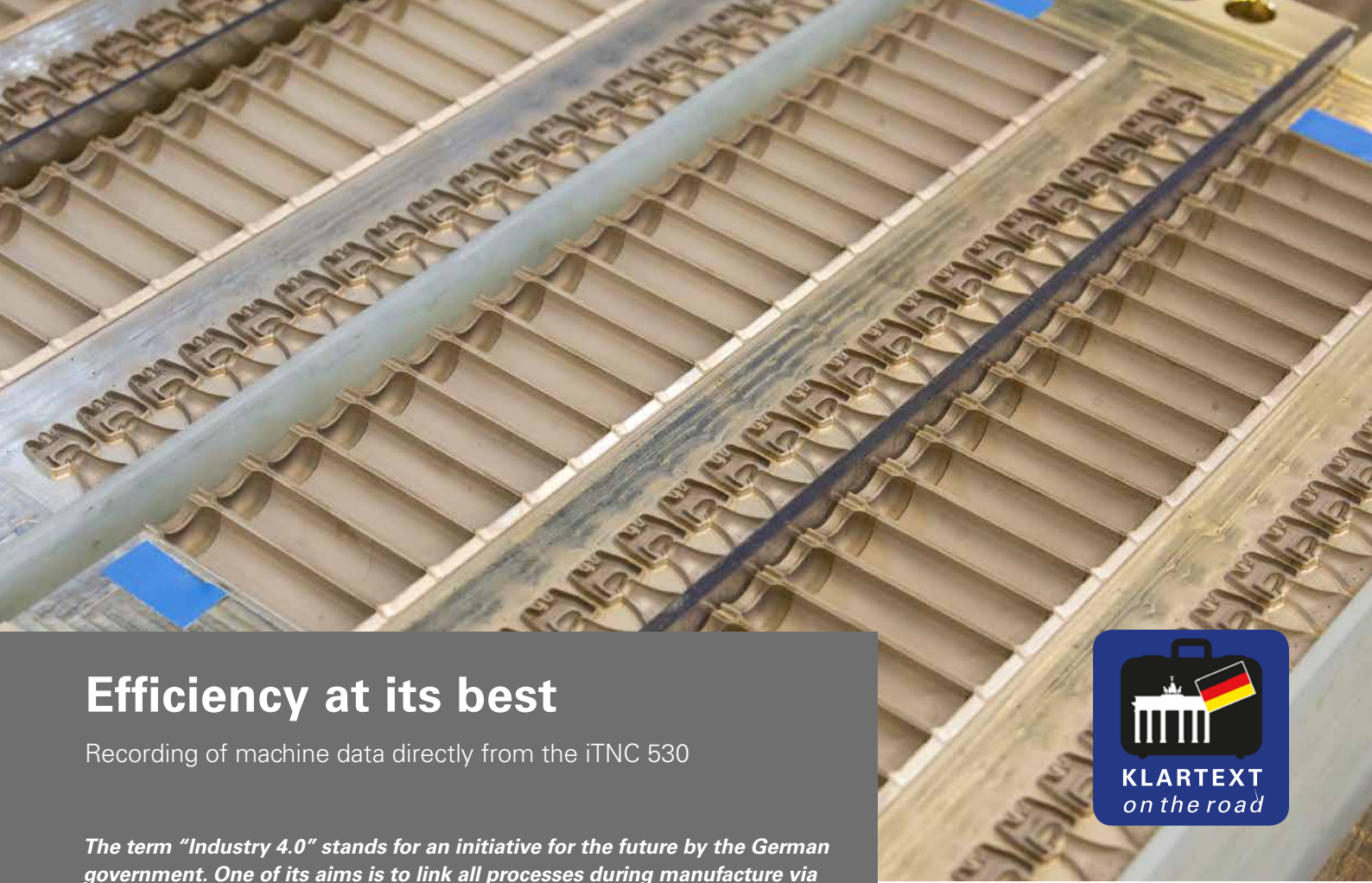

Efficiency at its best

Recording of machine data directly from the iTNC 530

The term “Industry 4.0” stands for an initiative for the future by the German government. One of its aims is to link all processes during manufacture via information systems to enable ever more individually designed products to be produced with a high level of automation. Efficiency with resources and the ability to adapt are intended to generate new chances for more competitive capacity.

The example of Kocher-Plastik demonstrates how the concept of a coherent connection of all processes during production to the latest technology serves to increase both efficiency and flexibility. In focus: A Mikron HPM 800 U HD from GF Machining Solutions with pallet changer, a HEIDENHAIN iTNC 530 directly connected with the operating data recording system, and highly motivated machine operators with excellent programming skills.



Hans Beißwenger, Armin Brehm and Stefan Bussmann (left to right) exploit all possibilities for digital work organization to achieve optimal machine capacity utilization.

Blow-fill sealing: Packaging machines from Kocher-Plastik Maschinenbau GmbH form, fill and seal plastic containers in a single work process. With breathtaking speeds and germ-free conditions, up to 34,000 ampoules or 10,000 bottles are produced hourly, filled with liquid pharmaceuticals.

Pharmaceutical producers worldwide depend on high-performance systems sourced from Sulzbach-Laufen in Baden-Württemberg, Germany. Each packaging machine requires several blow molds for the production process. They are constructed specifically for customers and then programmed and produced with in-house mold making. Production capacity is loaded to the full in times of brisk demand. Hans Beißwenger, Head of Machining: “We looked for solutions to help us utilize our machine tools better.” This was a real challenge because of the high diversity of forms and changing production quantities. Today, Kocher-Plastik benefits from a future-fit solution where a shop floor management system for the analysis, planning and control of production is linked to a high-performance machine park operated by a reliable team of experts.

Automation enables greater utilization

In the mold making facility at Kocher-Plastik, a Mikron HPM 800 U HD from GF Machining Solutions demonstrates in an exemplary way how simple automation together with the intelligent organization of machining orders leads to high levels of machine utilization. The high-performance machining center features a 7-fold pallet changer and a magazine for 210 tools. The pallet changer is easy to access and usually accommodates various workpieces, to be machined where possible in seamless processes. The machine is rapidly equipped due to the use of datum clamping systems. An iTNC 530 from HEIDENHAIN controls all functions needed for automation and features simple handling—decisive preconditions for utilizing the machine over longer time periods without interruptions.

A continuous flow of information and analysis improve efficiency

The shop floor management system manages the work orders. The operator has access to this directly on the machine, and following a personalized log-on, orders are displayed according to priority and the right job can then be selected. Optimal preparation includes a description of the workpieces with expected machining times, required tools and other details. This makes it easier for the operator to prepare the machine for longer, interruption-free use as well as the reliable testing of machining programs beforehand.

The current task of the operator, e.g. equipping, maintaining or programming, is communicated by the operator to the system via the iTNC 530 with the aid of simple interactions, and what the machine is currently doing is communicated

to the shop floor management system by the HEIDENHAIN iTNC 530 over an interface. This transfer of machine data is completely automatic.

An analysis of the linked data supplies a clear picture of the processes, and forms the basis for continuously optimizing the production process and automation. In this way Kocher-Plastik was able to significantly improve the utilization efficiency of its machine tools, and the evaluations also give a clear indication of production costs.

Competence as a factor for success

This digital organization of work does not limit the responsibility and expertise of the machine user, on the contrary—there's much more to it than simply equipping the pallet changer and pressing the start button. At Kocher-Plastik the machine



A compact, easily accessible pallet changer from GF Machining Solutions.



The iTNC 530 and the shop floor management system are directly connected for automatic recording of machine data.

"The machine ran over Easter – unmanned from Friday to Monday."

Hans Beißwenger, Head of Machining



Machining a bottle form with spherical end mills takes many hours, but is process-safe thanks to the iTNC 530.

operator organizes the entire production process on the machine tool. The forms themselves, often of wrought bronze or high-alloy tool steel, have complex free-formed surfaces and are machined with spherical end mills, and these production processes often run over many hours or days. The machine operator creates the start programs directly on the iTNC 530. These programs then insert the pallets and call the specific machining programs. Because much importance is placed on high levels of machine utilization, no problems or interruptions are tolerated in automated processing. As a consequence, the machine operator decides which workpieces can be machined in unmanned operation. This task not only assumes much experience but also reliable programming skills, as well as a control characterized by especially high process safety and optimal user friendliness.

Greatest safety is afforded by testing the programs directly on the control, and although Kocher-Plastik stipulates that the programs generated via CAD/CAM should be completely executable, the iTNC 530 machining simulation helps to reduce

risks that might cause interruptions. For example, only by testing on the machine can it be determined whether the tool magazine has all the requisite tools.

Exploiting the tool magazine potential

With 210 tool pockets, the magazine of the Mikron HPM 800 U HD provides good preconditions for interruption-free workpiece machining over long periods of time. It's a matter of making the most of this potential—the analysis of operating and machine data shows how ancillary times are nullified by the ideal application of tools. The success is shown in the effort needed for equipping. "The machine sometimes runs for up to six weeks before we have to change tools in the magazine," explained the machine operator Armin Brehm.

The availability and optimum use of the tools also lie in the responsibility of the program generators, who are supported by a tool database. A continuous flow of information, from testing the tools over the calling of machining programs through

to machine operation enables effective utilization planning. It has to be known beforehand which tools have to be in which magazine pockets, especially with machining over longer time periods, thus avoiding unnecessary idle times.

Generating programs more rapidly with distributed expertise

Kocher-Plastik places its trust in the very latest technology with its CAD/CAM system, shop floor management and automation solutions to achieve its targeted efficiency in production. The simple operation and programming of the HEIDENHAIN control is highly important in this sense—the CAD/CAM specialists use HEIDENHAIN cycles wherever possible in their programs. If, for example, repeat parts are machined with new tools at a later time, it's easy for the machine operator to modify the cutting data in the conversational dialog.

The innovative mold maker places an emphasis on the distribution of tasks for programming: The CAD/CAM department

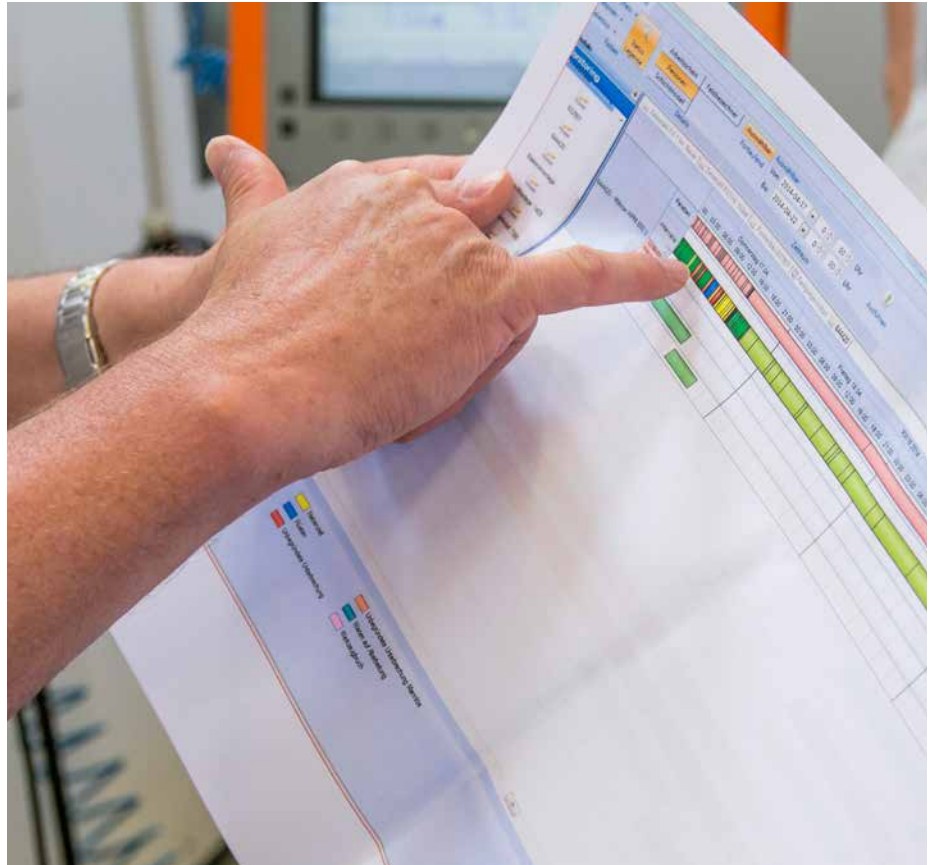
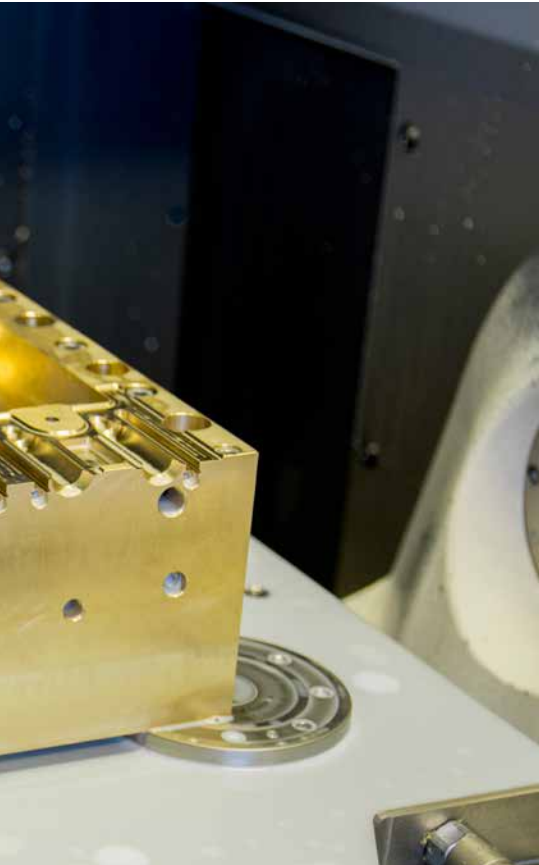

The interruption-free machining of various workpieces over several days is proof of the success of the connected features.

mainly concentrates on sophisticated 3-D geometries. 2-D geometries on the other hand are often passed to the colleagues directly on the iTNC 530, thus distributing the range of tasks over several shoulders, improving the level of expertise of the specific machine operator and making work on the machining center appealing and challenging as well.

Constant accuracy

The Mikron HPM 800 U HD has advanced dynamics and implements 5-axis machining with a direct drive, swiveling rotary table. The heavy-duty machine tool impresses Armin Brehm with its continuous level of accuracy: "During machine operation, the level of precision doesn't noticeably change even over longer machining cycles." The high rate of utilization ensures a stable temperature over longer time periods, so that recalibration of the rotary tilting axis is required less frequently. This is done once weekly with the KinematicsOpt TNC function. The iTNC 530 determines correction values for the rotary tilting axes with automatic touch probe

cycles in just a few minutes and modifies the kinematics table accordingly. This enables Kocher-Plastik to achieve a constantly high quality of machining that makes reworking the forms, for example by grinding, superfluous.

HEIDENHAIN touch probe cycles lead to higher accuracy and process safety even during machining, by analyzing critical workpiece dimensions to avoid reworking or scrap, and with the aid of a Blum laser the iTNC 530 also monitors the tools whenever they are exchanged.

Conclusion: Combined strengths lead to success

HEIDENHAIN controls are renowned for exploiting the accuracy potential of high-performance machine tool with a variety of perfectly matched functions. This is elementary for efficient mold making. The classic strengths of workshop programming enable the Kocher-Plastik operators to put their practical experience to advantage when setting up the automation.

The high machine utilization level and resulting increase in efficiency demonstrate that the combination of shop floor management and automation can lead to real competitive advantages. The direct linking of the HEIDENHAIN control to machine data recording aids analysis of the production processes, thereby reducing idle and ancillary times. The high efficiency levels can be maintained if the knowledge gained is consistently implemented with comprehensive information. This is particularly important for the strongly differing batch quantities and machining tasks for customer-specific forms.



Henry Hofmann frequently uses TURN PLUS and saves much programming time.



TURN PLUS: NC program at the push of a button

In record time: From the drawing to the finished part

Thanks to TURN PLUS, hardly any time is needed to generate turning programs, as at Voigt Spezialfertigung. The company headquartered near Zwickau in Germany mostly produces customer-ordered single pieces or small series, and repeat parts only infrequently. Hence their focus on creating machining programs especially quickly. This is where automatic program creation for the HEIDENHAIN lathe controls is advantageous.

While looking for a robust machine for simple turning cycles, the specialists from Voigt discovered DMT's fair stand, where they found a DMT CD 402 with a MANUALplus 620, the HEIDENHAIN control for cycle and CNC lathes. Committed product experts from the Lörrach-based lathe manufacturer offered to test the functions of the machine and control with turned parts live on the stand, which was no problem thanks to the easily-operated HEIDENHAIN control. That of course simplified the decision for purchasing the machine.

A simple start into productivity

The parts manufacturers became fully productive in a very short time with the MANUALplus 620. Since that time the lathe has proved to be highly reliable and simplifies the many different turning operations. Managing Director Andreas Voigt: "We don't know this month what we'll be producing next month." Because of this, many new machining programs have to be created quickly and simply, and for this reason Andreas Voigt and his team place special importance on the TURN PLUS function, now also available as an option for the MANUALplus 620.

The lathe operator Henry Hofmann is pleased about the easy use—he initially defines the workpiece blank via a simple dialog and then enters the contour via Interactive Contour Programming, or ICP for short. The contour can alternatively be imported directly from a DXF file. The control visualizes the turned part as an easily understandable line graphic, and Hofmann rapidly selects the individual contour elements via the number pad of the control and inputs the dimensions via simple form dialogs. Although the control permits differing creation strategies, he typically specifies the rough contour first, and then defines the transitions, such as chamfers. “Drawing the contour is so quick that it hardly pays to take the data from our CAD/CAM system,” said an enthusiastic Henry Hofmann.

Automatic program generation in practice

After creating the contour he assigns suitable tool pockets, and would usually have to define the machining sequence. However, the “default is almost perfect” for his applications. TURN PLUS uses a reasonable sequence of possible operations, such as “first transverse roughing, then longitudinal roughing” or “finishing inside, then finishing outside.” Users are then able to modify these for their specific tasks.

All that remains is the automatic program generation. Pressing the AWG “Automatic work plan generation” soft key suffices: The MANUALplus 620 creates the work specification from the input contour and with information from the technology database. For this purpose the HEIDENHAIN control selects suitable work strategies, tools and cutting data. This functions even for complex workpieces that need to be machined on the front face, rear side and lateral surfaces. The control almost provides too much for Henry Hofmann’s tasks. “Our fixtures are much too similar.” As a result, he simply keeps the preset values for feed rates, cutting speed and cutting depths, then implements the desired modifications later in the generated DIN PLUS program.

While the HEIDENHAIN control generates the program, the user is able to track the simulation of workpiece machining with an easy-to-understand graphic. The result is an executable DIN PLUS program that can be expanded and modified as desired by the machine operator.

More good parts thanks to reliable simulation

Henry Hofmann paid his compliments to the HEIDENHAIN control simulation. “Simulation on the MANUALplus 620 corresponds to real machining and is therefore really useful for preliminary control,” he said. Errors are rapidly identified. “What happens in the simulation also happens on the machine!” The user can select the most appropriate method of display for the simulation depending on the tool or operation, and the line display gives a rapid overview of the proportioning of cuts. The cutting path display is especially suitable for controlling the contours, and motion simulation faithfully reproduces the cutting process. This is achieved with the actual dimensions of the contour and cutting edge, including cutting radius, width and inclination. As a consequence, details of the machining or risks of collision are reliably detected prior to the actual operation.

Let’s get started!

Following rapid program generation by the control, the material is clamped and machining can start. The simple and largely automatic program generation provides decisive benefits for the parts manufacturer. “It saves a lot of time as well as unnecessary scrap, and also contributes importantly to our high quality levels,” said a convinced Managing Director Andreas Voigt.

MANUALplus 620: One control for all tasks

The MANUALplus 620 with the TURN PLUS function is not only ideal for a parts manufacturer having to supply components with very short lead times. Depending on the specific machine, operators can select whether they wish to run simple turning operations as cycles or more complex machining with CNC programs that they’ve generated with smart.TURN or directly in the DIN PLUS format. For this reason, using the MANUALplus 620 is highly beneficial where smaller and mid-sized batch sizes place special demands on flexible production.



Managing Director Andreas Voigt (on right) and lathe operator Henry Hofmann:
“Taking the decision for the DMT machine with MANUALplus 620 wasn’t difficult.”



The DCM software option monitors the working space of the machine for possible collisions.

Milling without collisions thanks to DCM

Dynamic Collision Monitoring (DCM) from HEIDENHAIN at KERN Microtechnik



“And then I just smashed into the laser load cell,” reports Thomas Mauer, reminiscing about his first crash several years ago. The precision master technician now works for KERN Microtechnik, a contract manufacturer of ultra-precision machines located in Upper Bavaria, Germany. The company uses iTNC 530 controls from HEIDENHAIN featuring DCM functionality, or Dynamic Collision Monitoring. DCM interrupts machining whenever a collision is imminent, thereby increasing safety for both the machine and its operator. KERN places its complete trust in this function both as a machine producer and in its capacity as a contract manufacturer to prevent damage to its precision machines.

DCM protects investments

The consequences of collisions may far exceed simple load cells, and repairing machine axes and spindles is costly. Added to this is the fact that machines may no longer function according to their original levels of accuracy following a collision, quite apart from deadline delays and capacity losses due to machine failures. “Crashes have definitely been prevented thanks to DCM, and these might well have caused up to 50,000 euros in plant damage,” said Dr. Dennis Janitza, Managing Director of KERN Microtechnik.

The DCM software option monitors tool movements in the machine room, both in automatic and set-up mode, and when collision is imminent, the HEIDENHAIN control halts machining, or in manual mode slows down the feed rate until a complete stop. KERN Microtechnik as a machine producer specifically recommends this wide-ranging function to

customers. “DCM makes sense for our customers even if just a single crash is prevented,” commented Dr. Janitza. As a consequence, KERN optimally adapts the function to each of its machines.

DCM takes into account all further components in the working space such as chucking equipment, fixtures, tools and tool holders as well as touch probes and other measuring equipment. The HEIDENHAIN control completely monitors the machining process and reliably avoids collisions, particularly in compact working spaces, such as in KERN precision machines.

Avoiding hazards in daily production

“With DCM, work is significantly more relaxed,” stated Thomas Mauer. Dangers lurk though in manual mode—often a high number of interfering contours are created when complex components

“We recommend DCM to customers, because avoiding even a single crash quickly pays the costs for this feature.”

Dr. Dennis Janitza, Managing Director, KERN Microtechnik

are initialized. Workpieces are often also filigree and tools are traversed near the fixtures. As a result, KERN often integrates the frequently complex fixtures as a model into clamp management. In stressful situations, it may often happen that the wrong axis direction key is pressed or a datum is erroneously set; DCM then reduces the speed before the potential danger point is reached, enabling the operator to keep control of any tricky situations.

On the other hand, with KERN precision machines and customer-specific axis configurations it may also occur that multi-axis traverse causes machine components to be exposed to collision danger. This is what DCM prevents, because with simultaneous 5-axis machining and rapid traverse motions, the operator cannot prevent a crash with the stop key in time. DCM stops during the program run and indicates to the machine operator via error messages and screen colors which components are on collision courses.

Following program cancellation, the iTNC aids safe retraction. It is often not clear, especially with tilted systems, in which direction a tool will continue, but the HEIDENHAIN control only permits the direction increasing the distance to the collision body.

DCM for real situations

Contract manufacturing at KERN Microtechnik processes customer orders on in-house KERN maximum-precision machining centers. A focus is placed on producing precision parts—components for the watch-making industry, medical technology or for measurement technology,



A broad and comprehensive solution—DCM collision monitoring, in addition to considering fixed machine components, also monitors tools and tool carriers...



... as well as chucking equipment and complex fixtures.

with component accuracies of down to 1 μm . The NC machining programs needed for this usually come from the CAM system and are also simulated for collision there—the CAM system using the CAD data of the component, tools, machine model and fixtures for this purpose.

CAM simulation however does not take into account real machining as subsequently implemented in the machine, and normally has no information as to how the control actually runs the machine axis traverse movements. The CAM system is also not aware of the paths from and to the tool changer and doesn't manage the preset table of the HEIDENHAIN control. In such situations the DCM function provides highly effective protection. This also applies to laser systems for tool monitoring mounted in the working space of the machine.

DCM checks for collision danger during real machining, and because DCM runs in real-time mode, subsequent program modifications or manual actions are not problematic.

High process reliability

"KERN Microtechnik stands for high precision in productivity," emphasized the Managing Director Dr. Janitza. This fact is underlined by the company's contract manufacturing in which series are run with high efficiency. A customer order can take up to 90 hours of machine time, and following this the results have to be exactly right—parts are required with the same, high dimensional accuracy, and failures are not permitted, ensuring cost-efficient orders. DCM makes processes safer, the function protecting machines even during unmanned shifts.

Conclusion

DCM, the dynamic collision monitoring software option for HEIDENHAIN controls, is an indispensable function in the opinion of KERN Microtechnik. It supplements not only the collision simulation of CAM systems, but also protects machines from setup all the way through workpiece machining. The function reliably monitors all real situations in the working space.

KERN Microtechnik

KERN Microtechnik develops and manufactures maximum-precision machine tools and is based in Eschenlohe, Upper Bavaria. It conducts contract manufacturing in Murnau. With these twin segments of production and application, KERN benefits from high levels of expertise transfer. KERN precision machines are controlled exclusively with the HEIDENHAIN iTNC 530.

+ www.kern-microtechnik.com

DCM – Dynamic Collision Monitoring

The DCM function, or Dynamic Collision Monitoring, interrupts machining in the event of an imminent collision. The control outputs an error message on the screen and displays the affected collision body in a graphic. Retraction is permitted only in the direction that increases clearance. DCM functions in both automatic and manual mode. Machine damage, often resulting in costly downtimes, can be avoided.

+ www.klartext-portal.de

No chance of a collision in the tight working space of a customer-specific KERN precision machine: DCM interrupts axis motion before a crash occurs.





Intelligent milling with residual material detection

iTNC 530 with software version 04

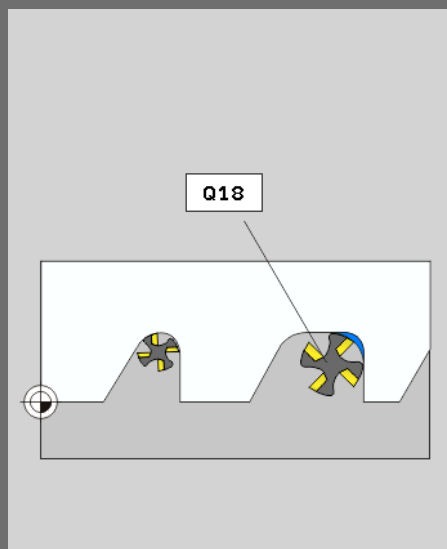

Cycle 25 CONTOUR TRAIN, together with Cycle 14 CONTOUR, machines open and closed contours. With the new residual material detection function, the cycle now mills more intelligently: The cutter only machines corners and radii not reached by the coarse roughing tool—without traversing the complete contour.

The new parameters:

Q18 – Coarse roughing tool: Number or name of the tool with which the TNC has already coarse-roughed the contour. The TNC calculates the contour sections still to be machined, depending on the diameter of the previously used cutter. The TNC then moves the tool to the appropriate positions. Enter "0" if no course roughing was carried out. The control machines the contour as possible with the active tool.

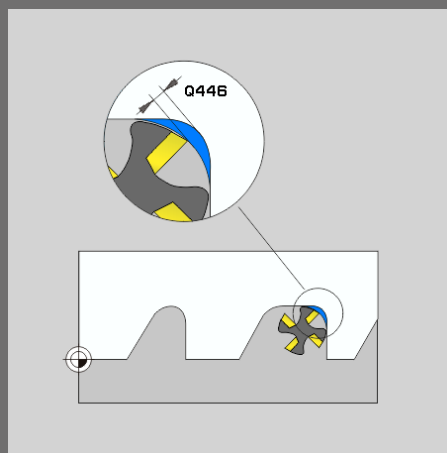

Q446 – Residual material: Thickness of the residual material from which the TNC no longer machines the contour. Default value: 0.01 mm

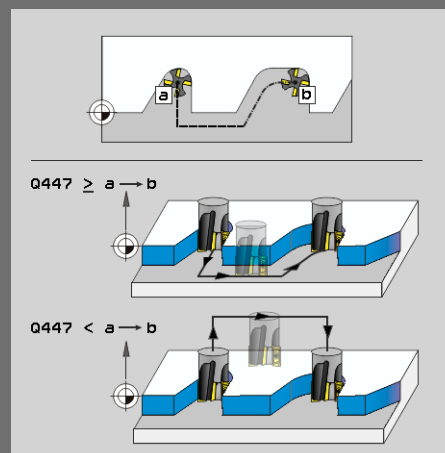

Q447 – Connection distance: Maximum distance between two areas to be fine-roughed, between which the tool is to move at the machining depth along the contour without a lift-off motion.

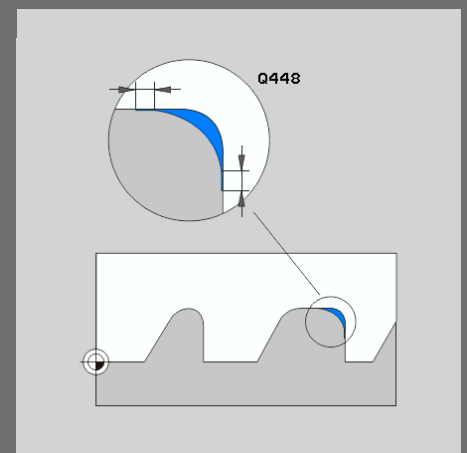

Q448 – Path extension: Length by which the tool path is extended at the start and end of the contour. The TNC always extends the tool path parallel to the contour.



The right choice for good service

Spotlight on: Functional and premium repair in practice

The Upper-Bavarian machine producer ALZMETALL is well-known for its robust, dynamic machining centers, and the company's service department also places major importance on performance and quality. The Klartext editors asked about how both the machine producer and its customers can benefit from the new option of selecting between functional or premium repair with the HEIDENHAIN service department.

A high-performance service department should fulfill the expectations of customers in the long run. After all, machines with high utilization levels benefit economic production methods, and idle times are undesired. If problems occur, a rapid and effective repair service maintains customer satisfaction. Although apparently that's not enough—a survey carried out by the HEIDENHAIN service department showed that customers also wish to determine the extent of services. The control manufacturer has responded in turn: Customers can now choose between functional or premium repair for many products and components.

Premium repair not only repairs all functions but also ensures a visually new condition for the device. Many machine

operators simply want perfect functionality though, and in these cases functional repair is ideal. With both services, repair is provided with a 12-month guarantee on complete device functionality.

The new selection possibility comes at the right time for the ALZMETALL service experts because if problems occur, customers frequently contact the machine manufacturer directly. It's then a matter of carrying out a rapid diagnosis and providing a suitable offer. This usually happens without problems, because the ALZMETALL service department has worked in close cooperation with the HEIDENHAIN service department for many years. On the one hand this enables the more tricky causes of a fault to be rapidly localized with the help of famil-



“The contact is excellent. There’s always someone to reach via the hotline... everything’s exactly right across the board!”

Wolfgang Krammer from ALZMETALL comments on direct cooperation with the HEIDENHAIN service department.



It’s the customer’s choice: Functional repair (left) or premium repair (right) are both technically optimal.

The service technicians Wolfgang Krammer and Alfred Wolferstetter as well as Manuel Schneckenpointner from Purchasing (left to right) are keen on the direct contact to HEIDENHAIN, and pass on the new advantages directly to their customers.

iar contact partners, and on the other it means that ALZMETALL does not need to stock replacement devices. The machine manufacturer passes on the new option of either functional or premium repair to its customers. Wolfgang Krammer, service technician at ALZMETALL, tells about a current service case where the functionality of a control keyboard was impaired. The customer requested the repair of the defective component, but exchanging it for a new keyboard was expressly not desired. Because demands for purely functional repairs are frequent, the machine manufacturer service department is pleased to offer an economic alternative.

In cases of repair, the ALZMETALL service department forwards the device to HEIDENHAIN, meaning the customer has to wait for the device if only the functionality is to be re-established, which may take several days with shipping. If no time should be wasted the exchange service is ideal—the defective device is replaced immediately with a repaired device with an optically new condition, and in such cases only the costs of premium repair are paid by the customer.

Most machine manufacturers keep exchange devices in stock, and in such cases it’s normal to restore a defective customer device via premium repair. The device is then put in stock and kept as an exchange unit.

ALZMETALL is convinced that the level of customer loyalty benefits from the expanded service offer. “We hope that our customers won’t approach independent service providers but that they see the benefits provided by the value of original parts and reliable guarantees. After all, our service is a part of our complete concept where the quality itself is primary—good service is an inherent part of our products.” A further advantage is long-term availability: HEIDENHAIN stocks main components and devices for up to 20 years.

Conclusion: The example of ALZMETALL demonstrates that both machine manufacturers and operators benefit from the new freedom of selection. The real winner is quality—HEIDENHAIN keeps its promise with original parts and its guarantee on repaired devices.



HEIDENHAIN

dynamic + efficiency

Sometimes you have to bundle all your forces to achieve your goal. This truth is no more valid in sports than it is in chip making on milling machines. Here the TNC control from HEIDENHAIN provides "Dynamic Efficiency" to find the potential hiding in your machine: for example higher metal removal rates with Active Chatter Control (ACC) combined with Adaptive Feed Control (AFC). With "Dynamic Efficiency" you become more productive, spare your machine, and attain longer tool service life.

DR. JOHANNES HEIDENHAIN GmbH, 83292 Traunreut, Germany, phone +49 8669 31-0, www.heidenhain.de

angle encoders + linear encoders + contouring controls + position displays + length gauges + rotary encoders